

# UPS

Uninterruptible Power System

**Line Interactive Network Protection**

**Pure Sine Wave Output UPS**

**Tower Models**

**600VA/ 800VA/ 1000VA/ 1250VA/  
1500VA/ 2000VA/ 2500VA/ 3000VA**

**Rack Mount Models**

**600VA/ 800VA/ 1000VA/ 1250VA/  
1500VA/ 2000VA/ 2500VA/ 3000VA**

**Extended Run-Time Models**

**1000AL/ 2000AL/ 3000AL**

**■ USER'S MANUAL ■**

# IMPORTANT SAFETY INSTRUCTIONS

## IMPORTANT SAFETY INSTRUCTIONS SAVE THESE INSTRUCTIONS

- **CAUTION (UPS Having Internal Batteries):** Risk of electric shock - Hazardous live parts inside this unit are energized from the battery supply even when the input AC power is disconnected.
- **CAUTION (No User serviceable Parts):** Risk of electric shock, do not remove cover. No user serviceable parts inside. Refer servicing to qualified service personnel.
- **CAUTION (Non-isolated Battery supply):** Risk of electric shock, battery circuit is not isolated from AC input, hazardous voltage may exist between battery terminals and ground. Test before touching.
- **WARNING (Fuses):** To reduce the risk of fire, replace only with the same type and rating of fuse.
- **WARNING:** Intend for installation in a controlled environment.
- **CAUTION:** Do not dispose of batteries in a fire, the battery may explode.
- **CAUTION:** Do not open or mutilate the battery, released electrolyte is harmful to the skin and eyes.
- **CAUTION:** A battery can present a risk of electric shock and high short circuit current. The following precaution should be observed when working on batteries  
  
Remove watches, rings or other metal objects.  
Use tools with insulated handles.
- To reduce the risk of electric shock, disconnect the UPS from the mains supply before installing a computer interface signal cable. Reconnect the powers cord only after signaling interconnections have been made.
- Servicing of batteries should be performed or supervised by personnel knowledge of batteries and the required precautions. Keep unauthorized personnel away from batteries.

When replacing batteries, replace with four 12V/7Ah

# TABLE OF CONTENTS

IMPORTANT SAFETY INSTRUCTIONS.....	i
TABLE OF CONTENTS.....	ii
INTRODUCTION.....	iii
1. PRESENTATION.....	1
2. INSTALLATION.....	9
3. OPERATION.....	13
4. ALARM.....	14
5. SOFTWARE AND INTERFACE.....	14
6. MAINTENANCE AND STORAGE.....	16
7. BATTERY AND BATTERY CABINET.....	17
APPENDIX A. TROUBLESHOOTING.....	18
APPENDIX B. SPECIFICATIONS.....	19

Revision 1.9  
Revised April 17, 2002.

# INTRODUCTION

## SAVE THESE INSTRUCTIONS

### **Please read and save this manual!**

Thank you for selecting this uninterruptible power system (UPS). It provides you with a perfect protection for connected equipment. The manual is a guide to install and use the UPS. It includes important safety instructions for operation and correct installation of the UPS. If you should have any problems with the UPS, please refer to this manual before calling customer service.

### **Please save or recycle the packaging materials!**

The UPS's shipping materials are designed with great care to provide protection within delivery. These materials are invaluable if you ever have to return the UPS for service. Damage happened during transit is not covered under the warranty.

### **Intelligent microprocessor control**

The product is an advanced line-interactive UPS based on microprocessor control. This means that it operates with the newest technology, high performance and powerful function.

The line-interactive UPS is an intelligent protector and provides pure, reliable AC power to the critical loads - protecting them from utility power blackout, swells, sags, surges and interference. The loads could include sensitively medical instruments, computers, telecommunication systems, and industrially automatic equipment. Under power normal condition, the line-interactive design enables the system to adjust and filter power fluctuations continuously and automatically. In the event of power failure, it can provide immediately back-up power from the batteries without any interruption. Complete transference will be achieved within 4m seconds, with no interruption.

Beside this, when the utility power is connected, the charger would work automatically even under power switch is OFF. Furthermore, in order to save the battery energy, UPS can automatically turn it off under backup mode if none of the connected loads is operating.

### **Advanced battery management**

The visual and audible indications of the UPS present the battery's status including capacity degree and battery condition. Self-test function let UPS detect a weak battery before it is put into service. The UPS normally perform a self-test at power up and manual self-test condition. Self-test function can be conducted manually with the ON/TEST switch at any time.

### **Advanced monitoring software**

The line-interactive UPS and UPS-MON series monitoring software (optional kits) make your computer operate intelligent and provide you with the ability of perfect protection of your critical devices. The software is available for most operation systems and is supplied with a communication cable that connects to the UPS.

Note: There is no guarantee that interference to radio/TV will not occur in a particular installation. If this UPS causes interference to radio or television reception, which can be determined by turning the UPS off and on, the user is encouraged to try to correct the interference by one or more of following measures:

1. Connect the equipment to an outlet at a circuit different from the connected radio/TV.
2. Increase the separation between the equipment and the receiver or reorient the receiving antenna.

# 1. PRESENTATION

## 1.1 Front LED Panel

**1.1.1 “ON/TEST” button:** With the UPS plugged in, press the ON/TEST button to turn on the UPS and power the loads. ON/TEST also activates the UPS’s self-test and utility line voltage displays.

**1.1.2 “OVERLOAD” indicator (RED LED):** The LED lights when the loads connected to the UPS exceed the UPS’s capacity. See Section 5.3.

**1.1.3 “BACK UP” indicator (GREEN LED):** The LED illuminates when the UPS is supplying battery power to the loads.

**1.1.4 “REPLACE BATTERY” indicator (RED LED):** The LED illuminates when the UPS’s battery is no longer useful and must be replaced..

Note: When replace battery, disconnect the utility power then open the case and take notice of the battery’s polarity while install the new battery to avoid short circuit. See section 8.

**1.1.5 “BUCK AVR (VOLTAGE REDUCTION)” indicator (YELLOW LED):** The LED illuminates when the UPS is correcting a high utility voltage condition. The loads receive normal power.

**1.1.6 “LINE NORMAL” indicator (GREEN LED):** The LED illuminate when the line input voltage is normal.

**1.1.7 “BOOST AVR (VOLTAGE BOOST)” indicator (YELLOW LED):** The LED illuminates when the UPS is correcting a low utility voltage condition. The loads receive normal power.

**1.1.8 LOAD bar graph:** The display shows the power being drawn by the load.

**1.1.9 POWER bar graph (BATTERY CHARGE):** The display shows the present battery charge as a percentage of battery capacity.

**1.1.10 “OFF” button:** Press the OFF button to turn off the UPS and the loads.

## 1.2 Front LCD Panel

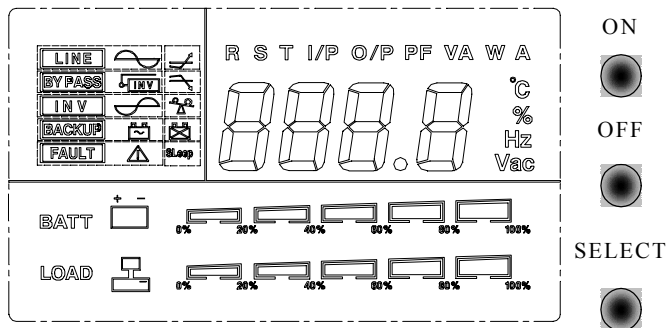

**1.2.1 “LINE” indicator:** The indicator illuminates when the line input voltage is normal.

**1.2.2 “BY PASS” indicator:** The indicator illuminates when the loads are supplied from the utility power, through the by-pass direction.

**1.2.3 “INV” or “INVERTER” indicator:** The indicator illuminates when the output power of UPS is supplied from the inverter circuit.

**1.2.4 “BACKUP” indicator (LCD Panel only):** The indicator illuminates when the power is supplied from the batteries.

**1.2.5 “FAULT” indicator:** It shows something wrong concerning about the UPS.

**1.2.6 “ON” button:** With the UPS plugged in, press the “ON” button to turn on the UPS and power the loads. “ON” also activates the UPS’s self-test and utility line voltage displays.

**1.2.7 “OFF” button:** Press the OFF button to turn off the UPS and the loads.

**1.2.8 “SELECT” button (LCD Panel only):** The relevant value appears on the upper screen. There are four display modes can be selected.

Output voltage display  
Input voltage display  
Input frequency  
Temperature inside the UPS  
Output frequency.  
Load level at percent.

**1.2.9 “BATT” bar graph (RECTANGLE INDICATOR):** The rectangle indicator shows the percentage of battery capacity.

**1.2.10 “LOAD” bar graph (RECTANGLE INDICATOR):** The indicator shows the power being drawn by the load.

**1.2.11 “FAULT” codes (LCD Panel only):** The relevant value appears at the upper screen. There are seven kinds of fault modes can be displayed.

Err0: UPS Fault.

Err1: Warning of overload. (exceeding 120%)

<u>Load Indicator</u>	<u>% of Load Value</u>	<u>Battery Indicator</u>	<u>% of Bat Level</u>
Light no.5	over 96%	Light no.5	over 91 %
Light no.4	76-95 %	Light no.4	76-90 %
Light no.3	51-75 %	Light no.3	51-75 %
Light no.2	26-50 %	Light no.2	26-50%
Light no.1	10-25 %	Light no.1	0-25%

## 1.3 Rear Panel

### 1.3.1 TEL./MODEM connector

Telecom transfer ports provide users to extend the applications.

● **Caution:** To reduce the risk of fire, use only No. 26AWG or larger telecommunication line cord.

### 1.3.2 EXTERNAL BATTERY PACK CONNECTOR (optional)

**CAUTION:** Use only factory supplied or authorized connecting cable for external battery!

**CAUTION:** Use only factory supplied or authorized SNMP monitoring cable!

### 1.3.3 OUTPUT POWER RECEPTACLES

### 1.3.4 AC INPUT POWER RECEPTACLE

### 1.3.5 INPUT CIRCUIT BREAKER/ FUSE

It trips when the connected loads exceed the protected receptacle's capacity, The center plungers of the circuit breakers/ fuse extend when tripped.

### 1.3.6 SITE WIRING FAULT INDICATORS (RED LED)

It comes on when the UPS is connected to an improperly wired AC power outlet.

Note: This device is available on 110 Vac model only.

### 1.3.7 COMPUTER INTERFACE

Provide both RS-232 and relay signal to support NOVELL, UNIX, DOS, WINDOWS and other operating systems.

### 1.3.8 SNMP INTERFACE PORT (optional)

Provide the SNMP adapters for 10-BaseT Ethernet and Token Ring connectors. Through RS232 communication port, the SNMP adapter make your UPS becomes "SNMP manageable", provide a real time UPS and power status information for the network manager.

Note: It's not necessary to use this function.

# FRONT VIEW

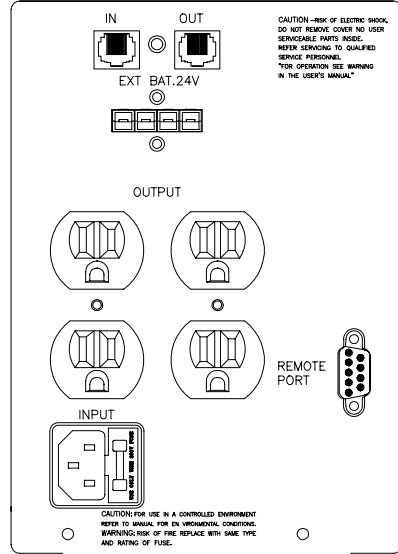
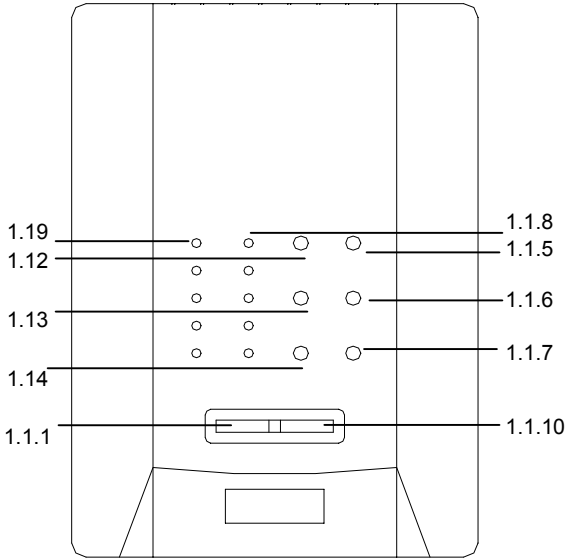

**1KAL (220V)**

# REAR VIEW

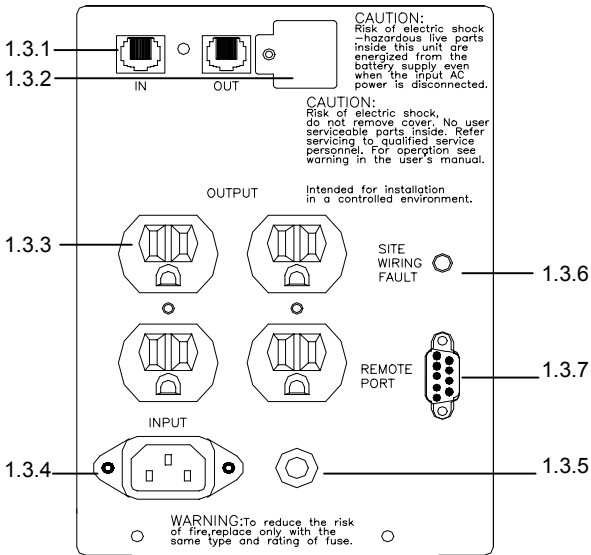

**600~1250VA (110V)**

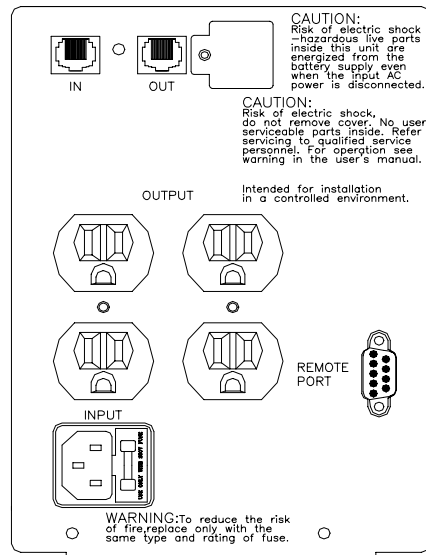

**600~1250VA (220V)**



# REAR VIEW

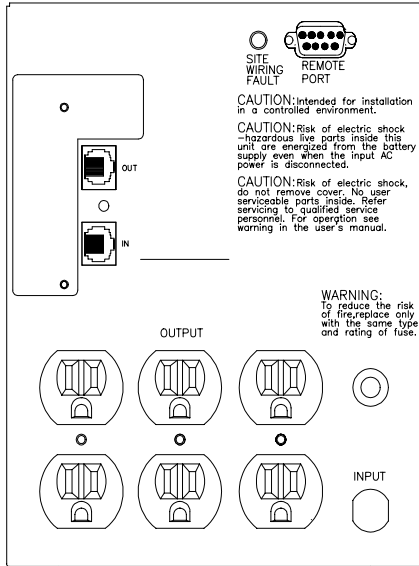

**1.5K/2KVA (110V/220V)**

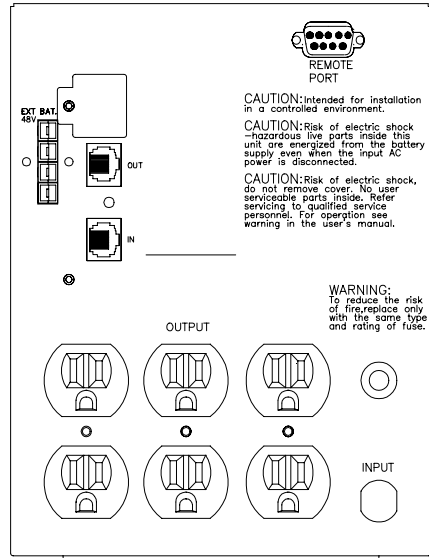

**2KAL(110V)**

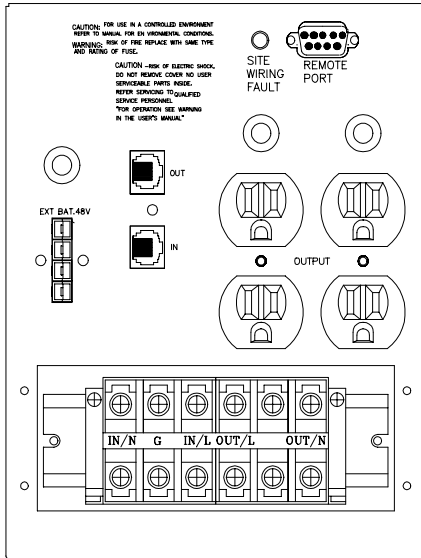

**3KVA/3KAL(110V)**

# REAR VIEW

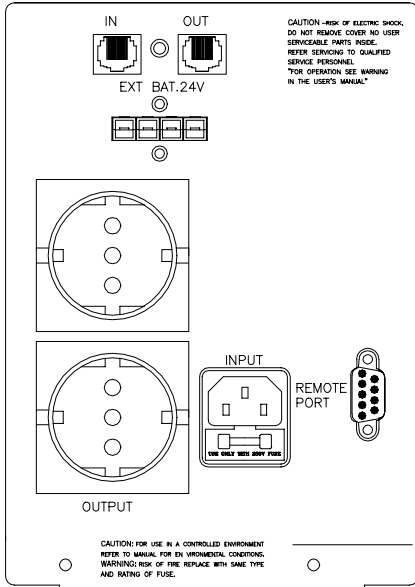

**1KAL(220V)**

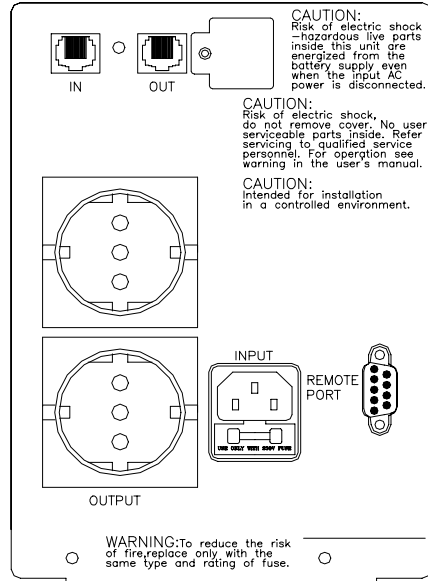

**600VA/800VA/1KVA/1.25KVA(220V)**

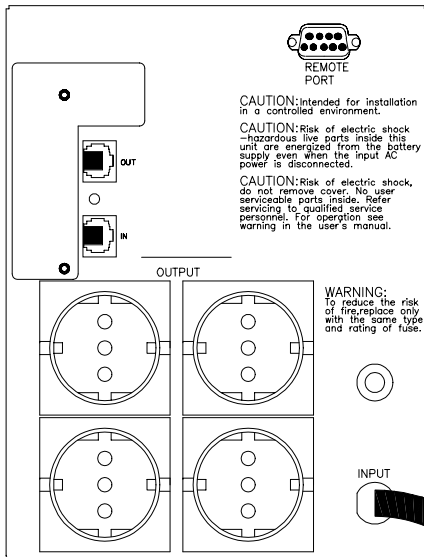

**1.5KVA/2KVA/2.5KVA(220V)**

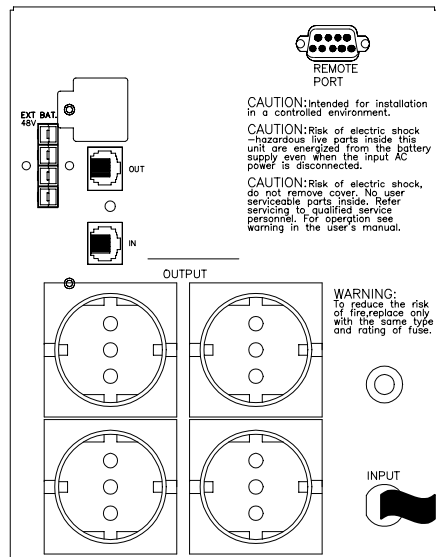

**2KAL/3KVA/3KAL(220V)**

# FRONT VIEW ( 800~3KVA(L) RM)

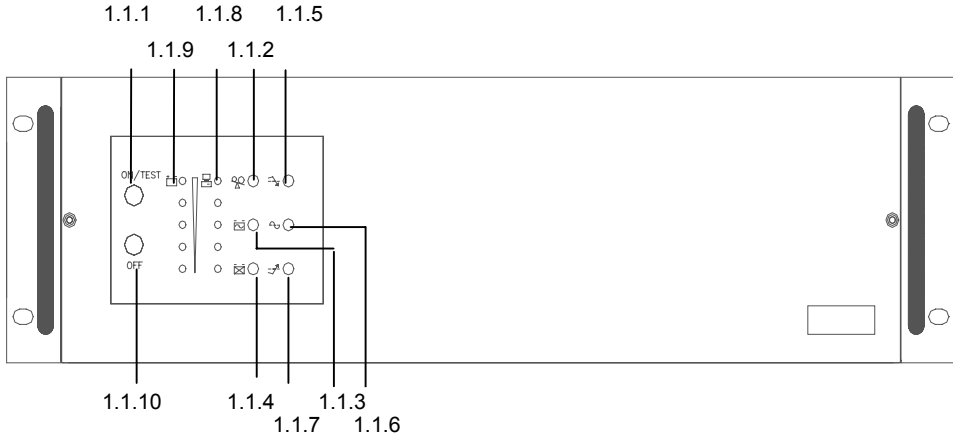

## REAR VIEW

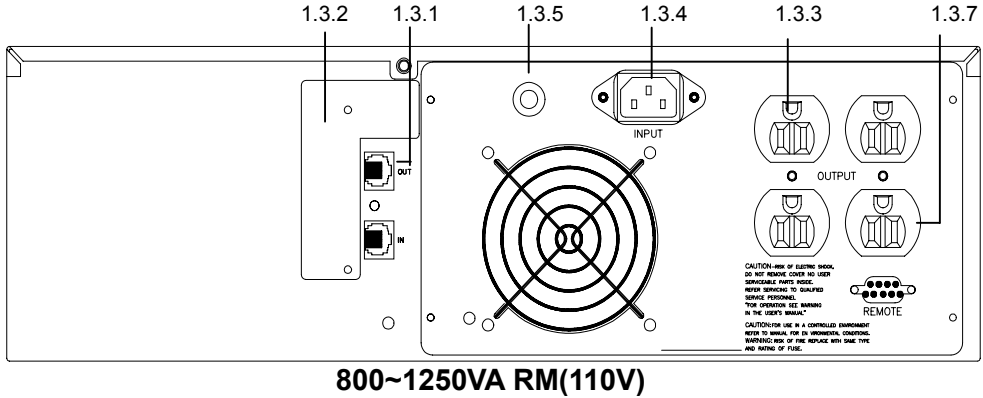

**800~1250VA RM(110V)**

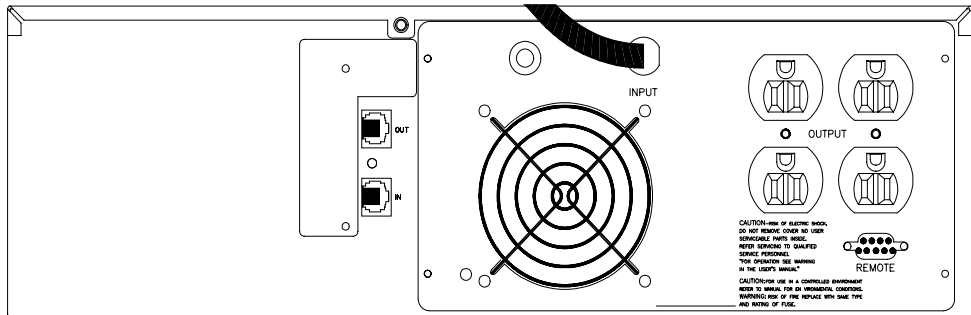

**1.5K~2.5KVA RM(110V)**

# FRONT/ REAR VIEW

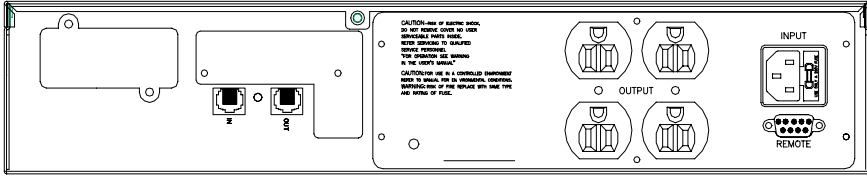
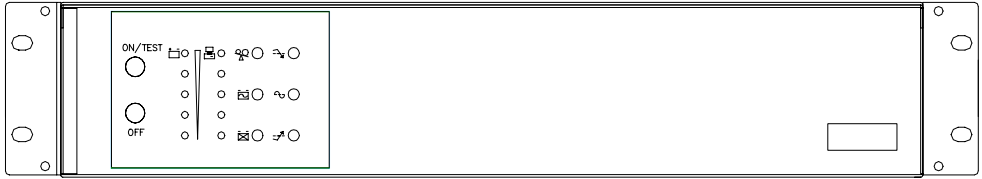

## 600VA RM (2U)

## 2. INSTALLATION

Inspect the UPS upon receipt. The packaging is recyclable; keep it for reuse or be disposed of properly.

**2.1 Placement:** Install the UPS in a protected area with adequate flowing air and free of excessive dust. Do not operate the UPS where the temperature and humidity is out of the specified limits. 2.5cm (1 inch)

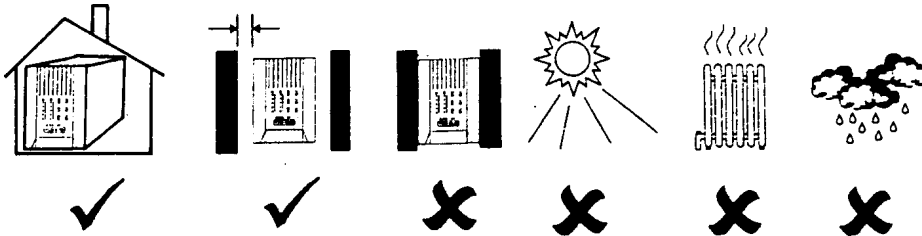

**2.2 Connect Computer Interface (optional):** UPS-MON series software (or other power management software) and an interface kits can be used with this UPS. Use only kits supplied or approved by the manufacturer. If used, connect the interface cable to the 9-pin computer interface port on the back panel of the UPS.

Note: Computer interface connection is optional. The UPS works properly without a computer interface connection.

**CAUTION:** Use only factory supplied or authorized UPS monitoring cable!

**2.3 Connect external battery pack (optional):** Before connecting, make sure the external battery pack and the connector cable are compatible.

Note: External battery connection is not necessary. The UPS works properly without external battery pack connection. (Except AL models only)

**CAUTION:** Use only factory supplied or external battery connection cable!

**2.4 Charge the battery:** The UPS charges its battery whenever it is connected to utility power. For best results, charge the battery for 8 hours in the initial use.

**2.5 Connect to Utility:** See figure a. Please check the following items to connect the AC input power to terminal block and power up the UPS.

**2.6 Connect the loads:** Connect the loads with the terminal block at the rear of the UPS. To use the UPS as a master on/off switch, make sure all of the loads are switched on.

**CAUTION:** Never connect a laser printer or plotter to the UPS with other computer equipment. A laser printer or plotter periodically draws significantly more power than when its idle status, and may overload the UPS.

**2.7 Check the Site Wiring Fault Indicator:** After plugging in the loads and the UPS, check the site wiring fault indicator on the rear panel. See section 3.17 for location of the indicator on the back panel. It lights if the UPS is plugged into an improperly wired AC power outlet. Wiring faults detected include ground, hot-neutral polarity reversal, and overloaded neutral circuit.

**2.8 Installations with accessories of “Vertical” and “Wall-mounted” types:** Please install the vertical and wall-mounted types of units according to the following illustration.

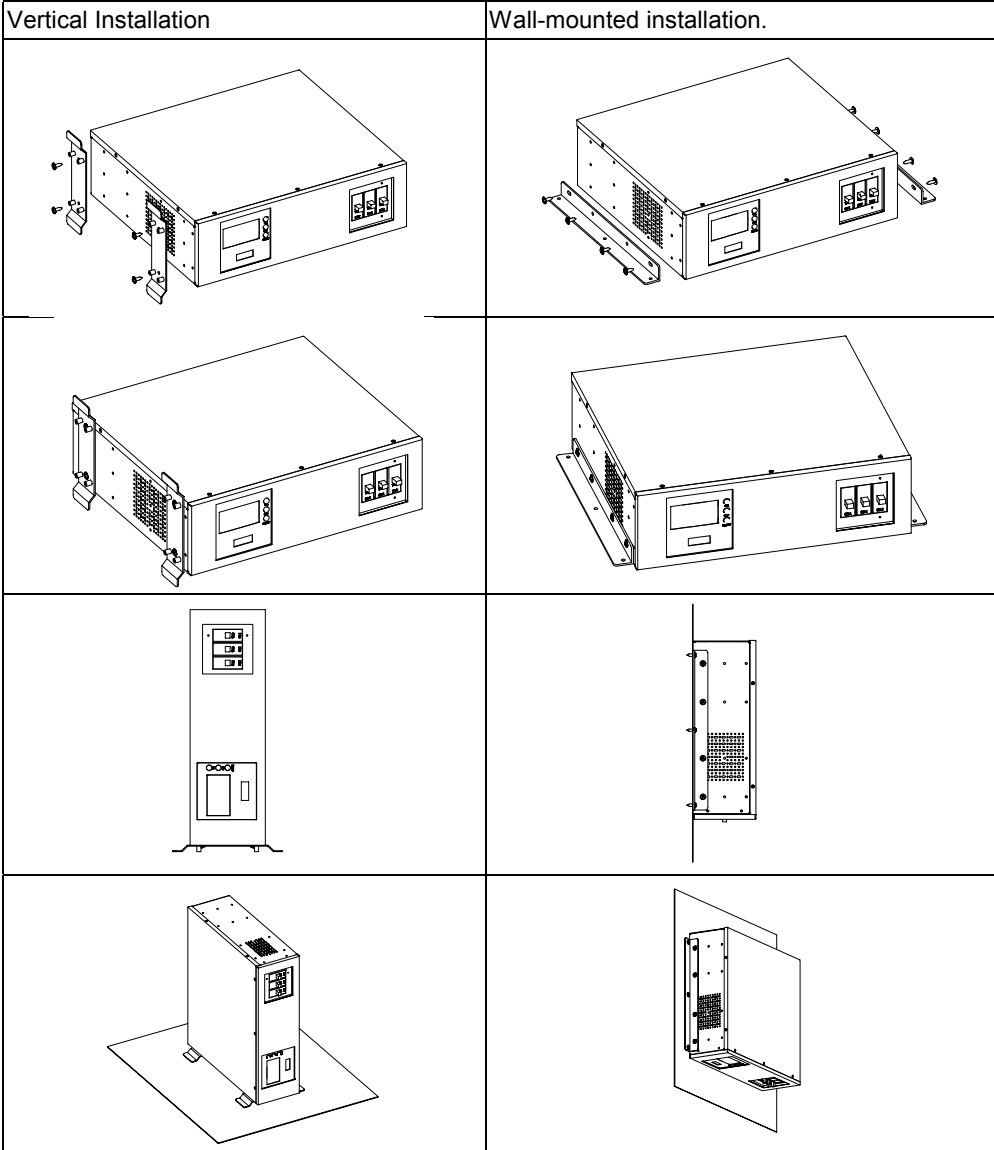

**2.9 Installation with accessories of “Rack-mounted” types:** Please install the types of units according to the following illustration.

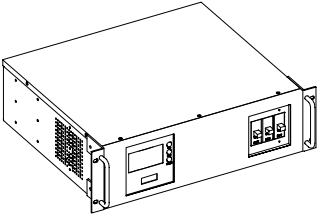
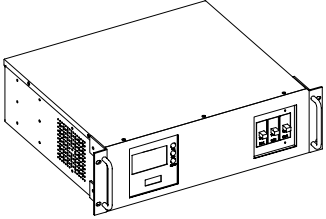
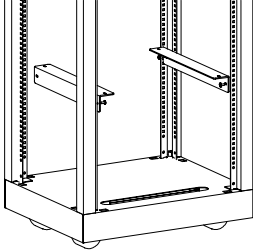
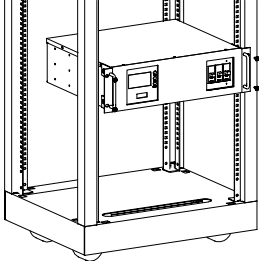
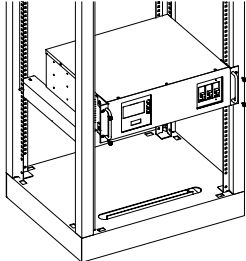
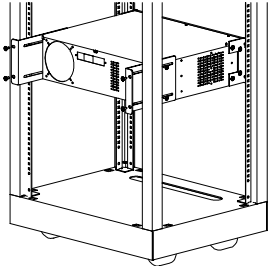
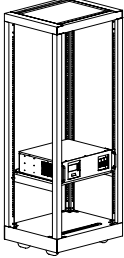
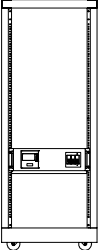
<p>Installation with bottom bracket. Part No: RMB-06, 2 PCS. Screw: M5*11, 4 PCS.</p>	<p>Installation with rear bracket Part No: RMB-01, 2PCS. Screw: M5*11, 4 PCS.</p>
	
	
	
	

**2.10 Installation with accessories of “Stack” types:** Please install the types of units according to the following illustration.

Stack installation

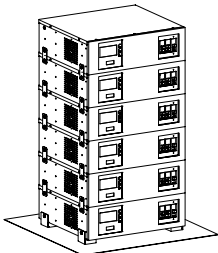
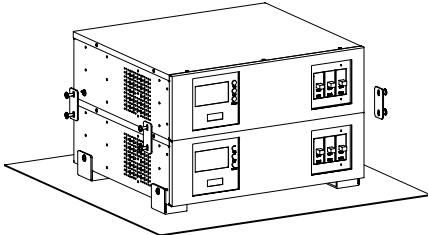
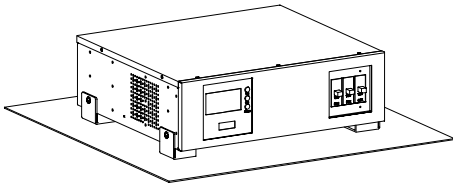
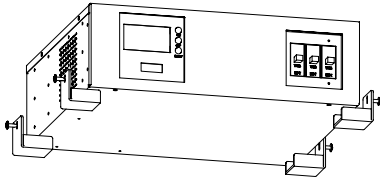



## 3. OPERATION

**3.1 Switch on:** While utility input is connected to the UPS, press the "ON" button and keep pressing over than 0.5 second. After that, connect the electrical cords of the equipment that is going to be used such as computer or monitor with the terminal on the rear panel of UPS.

Don't overload the machine with all the equipment used. The buzzer will beep continuously to indicate overload status. UPS will shut down automatically to protect the machine.

**Attention:** If the power of UPS isn't supplied by utility but by the internal batteries to engage the UPS, press the "ON" button and keep pressing for over 3 seconds.

**CAUTION:** Never connect a laser printer or plotter to the UPS with other computer equipment. A laser printer or plotter periodically draws significantly more power than when its idle status, and may overload the UPS.

**3.2 Switch off:** By pressing and holding OFF button until the "LINE NORMAL" or "BACK UP" LED off.

**3.3 Silence:** When UPS is under "BACKUP" mode, press "ON" button more than 1 second to silence the audible alarm. (The function is disable when UPS is under condition of "LOW BATTERY" or "OVERLOAD")

Note: At back-up mode, UPS can be automatically turned off if none of the connected loads is operating.

**3.4 Self-test:** Use the self-test to verify both the operation of the UPS and the condition of the battery. In normal utility power, push the ON/TEST button more than 1 second and UPS performs a self-test function. During the self-test, the UPS operates a back up mode.

Note: During the self-test, the UPS briefly operates the loads on-battery (the on-battery LED comes on).

If the UPS passed the self-test, it returns to line-interactive operation. The on-battery LED goes off and the line-interactive LED goes on steadily. If the UPS is failed to pass the self-test, it returns to line-interactive operation and lights the replace battery LED. The loads are not affected. Recharge the battery overnight and perform the self-test again. If the replace battery LED is still on, ask our nearest dealer to replace battery.

**3.5 Load bar graph:** The 5-LED display (See section 2.8 for location of the indicator on the front panel) shows the power drawn from the UPS by load. The display indicates the percentage of the UPS's rated capacity. For example. If three LEDs are lit, the load is drawing between 50% and 67% of the UPS's capacity. If the UPS is overloaded, the overload LED lights and alarm sounds. See section 5.3

**3.6 Battery charge bar graph:** The 5-LED display (see section 3.9 for location of the indicator on the front panel) shows the present charge of the UPS's battery as a percentage of the battery capacity. When all five LEDs light, the battery is fully charged. When only two LED lights, the battery can supply less than two minutes of run time for the load.

**3.7 Cold start:** When the UPS is off and there is no utility power, use the cold start feature to apply power to the loads from UPS's battery. Press the ON/TEST button (see section 3.1 for location of the indicator on the front panel) until the UPS beeps.

**3.8 Shutdown mode:** In shutdown mode the UPS stops supplying power to the load, waiting for return of utility power. If there is no utility power present, external devices (e.g., servers) connected to the computer interface can command the UPS to shutdown. This is normally done to preserve battery capacity after the graceful shutdown of protected servers. The UPS will scroll the front panel indicators sequentially in shutdown mode.

## 4. ALARM

**4.1 “BACKUP”(slow alarm):** When the UPS is working under “BACKUP” mode, the UPS would emit audible alarm. The alarm stops when the UPS is return to “LINE” mode operation. Anyone can stop the alarm by press the “ON” button during backup mode.

**Attention:** The alarm of “BACKUP” is going to beep every four seconds. (Slow-speed beep).

**Attention:** The UPS provides mute function for the warning. When the beeping sound occurs, press "ON" to stop it; and press "ON" again to regain the sound.

**4.2 “LOW BATTERY” (rapid alarm):** In the “BACKUP” mode, when the energy of battery becomes to lower level. (about 20%~30%) The UPS beeps rapidly until the UPS shuts down from battery exhaustion or returns to “LINE” mode operation.

**Attention:** The alarm of the batteries caused by low voltage beeps every second. (Fast-speed beep).

**Attention:** The rapid alarm under “LOW BATTERY” condition can't be erased.

**4.3 “FAULT” (continuous alarm):** Here is listing some “FAULT” conditions as following for reference.

4.3.1 “err 0” (LCD Panel only)

The UPS emits continuous beeps and the “FAULT” illuminates when the UPS fails.

4.3.2 “err 1” (LCD Panel only)

When the UPS is working under overload condition (the connected loads exceed the maximum rated capacity), the UPS will emit continuous alarm to warn an overload condition. In order to protect the unit and the loads, the UPS will be automatic shutdown. Disconnect nonessential devices from UPS to eliminate the overload alarm.

## 5. SOFTWARE AND INTERFACE PORT

**5.1 Power Monitoring Software:** The UPS-MON series software (or other power monitoring software) is applied standard RS-232 interface to perform monitoring functions, and then provides an orderly shutdown of a computer in the event of power failure. Moreover, UPS-MON displays all the diagnostic symptoms on monitor, such as Voltage, Frequency, Battery level and so on. The software is available for DOS, Windows 3.1x, Windows 95, Windows NT V3.5 or later, Novell Netware and others. Call your dealer for more information on computer OS compatible solutions.

**5.2 Interface Kits:** A series of interface kits is available for operation systems that provide UPS monitoring. Each interface kit includes the special interface cable required to convert status signals from the UPS into signals which individual operating system recognize. The interface cable at UPS side must be connected to REMOTE PORT, at computer side can be either COM 1 or COM 2. The other installation instructions and powerful features please refer to READ.ME file.

**CAUTION:** Use only factory supplied or authorized UPS monitoring cable!

**5.3 The characteristics of computer interface port:** The computer interface port has the following characteristics:

The communication port on the back of the UPS may be connected to host computer. This port allows the computer to monitor the status of the UPS and control the operation of the UPS in some cases. Its major functions normally include some or all of the following:

- To broadcast a warning when power fails.
- To close any open file before the battery is exhausted.
- To turn-off the UPS.

Some computers are equipped with a special connector to link with the communication port. In addition, special plug-in cord may be needed. Some computers may need special UPS monitoring software. Contact your dealer for the details on the various interface Kits.

**5.4 The pin of computer interface port:** The pin of computer interface port has the following characteristics:

- 5.4.1. Pin 5 and 2 are open collector outputs that must be pulled up to a common referenced supply no greater than DC +40V. The transistors are capable of a maximum nonconductive load of DC 25 mA, Use only pin 7 as the common.
- 5.4.2. Pin 5 generates a High to Low signal when the battery inside the UPS has less than 5 minutes back up time left.
- 5.4.3. Pin 2 generates a High to Low signal when the line is fail.
- 5.4.4. The UPS will shut down when a high RS-232 level is sustained on pin 6 for 0.36 seconds.
- 5.4.5. Pin 9 is the RS-232 data output.
- 5.4.6. Pin 6 is also RS-232 data input (RxD)

NOTE:

- 1. Switch rating +40V, 0.25A non-inductive.
- 2. Pin 7 should be connected to ground only.

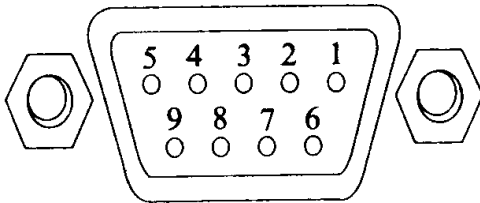

#### Communicating Interface Port

We provide a standard RS232 line (that is compatible with DB9 line) socket on the rear panel of UPS. That port possesses several signals as explained below:

Pin#	Function Explanation	I/O
2	Power Fail-normally open status, will become closed during active	OUTPUT
4	Reference GND for pin2,5	OUTPUT
5	Battery Low- normally open status, will become closed during active	OUTPUT
6	Remote shutdown UPS-keep this pin at high voltage(+5V~+12V) 500ms to shutdown UPS. Activates at battery mode	INPUT
7	Reference GND for pin6	INPUT

# 6. MAINTENANCE AND STORAGE

## 6.1 Maintenance

- 6.1.1. Keep the unit clean and vacuum the ventilation intake periodically.
- 6.1.2. Wipe with soft loose and damp cloth.
- 6.1.3. Check for loose and bad connections monthly.
- 6.1.4. Never leave the unit on an uneven surface.
- 6.1.5. Position the unit to allow at least 10 cm clearance between the rear panel and the wall. Keep the ventilation intake open.
- 6.1.6. Avoid direct sunlight, rain and high humidity.
- 6.1.7. Stay away from fire and extremely hot location.
- 6.1.8. Do not stack materials on top of the unit.
- 6.1.9. The unit should not be exposed to corrosive air.
- 6.1.10. The normal operating temperature is 0-40 °C.

**6.2 Storage conditions:** Store the UPS covered and upright in a cool and dry location, with its battery fully charged. Before storing, charge the UPS for at least 4 hours. Remove any accessories in the accessory slot and disconnect any cables connected to the computer interface port to avoid unnecessary draining the battery.

## 6.3 To extend the storage:

- 6.3.1. During the environment where the ambient temperature is -15 to +30 °C (+5 to +86 °F), charge the UPS's battery every 6 months.
- 6.3.2. During the environment where the ambient temperature is +30 to +45 °C (+86 to +113 °F), charge the UPS's battery every 3 months.

# 7. BATTERY AND BATTERY CABINET

## 7.1 Battery's life of UPS

The battery's life of UPS is about 3-6 years under normal usage.

**7.2 Installation of battery cabinet and UPS (For AL and AXL models only):** Please follow the listed steps to complete the installation.

7.2.1 Turn off the UPS and remove the connector metal cover from the back panel of UPS.

7.2.2 Connect the battery cabinet's DC wire to the UPS and fix the metal cover via a screwdriver. Beside this, make sure the connection is reliable.

7.2.3 Turn on the UPS and plug the loads behind the UPS.

**CAUTION:** Do not dispose of battery in fire.

**CAUTION:** Do not attempt to open the battery.

**CAUTION:** The following precautions should be taken when replacing the battery

- a. Remove watches, rings, etc...
- b. Use tools with insulated handles

# APPENDIX A TROUBLESHOOTING

Problems	Possible Reasons	Solutions
1. UPS can't operate after pressing On/Off switches 2. No lights on, no warning sounds	Input power source mistake	Check out the power source
	Non-fuse switch on the rear panel hasn't been opened	Press the non-fuse switch to its "on" position
	Time of pressing the ON button is too short	Keep pressing the ON button over 1 second
	Output short circuit or overload on UPS	Turn off UPS, take off all load to make sure there are no problems on it or any internal short circuit. Keep pressing the ON button over 1 second
Indicates no utility, and it warns every several seconds	No power source input	Check out the input power source
	Non-fuse switch on the rear panel hasn't been opened	Press the Non-fuse switch to its "on" position
Fault light is on, the buzzer keeps beeping	UPS is broken	Contact the dealer or service center for help
Buzzer keeps beeping	Overload	Take off some load
Utility Indicating light is shining	There is an open circuit on UPS input protector	Move the Input Non-fuse switch back to its normal position, re-engage UPS
	The voltage of utility is exceeding UPS input range	Save the digital data and shutdown the applying program to make sure utility is within UPS range
Available time of the batteries is too short	1. Batteries haven't been charged 2. UPS overload 3. Batteries are aged and can't be charged fully	Keep UPS "ON" for over 3 hours to recharge the batteries. Check out the loading and take off any non-crucial load equipment
	The charger is out of order	Contact the dealer or service center for help
The battery's light is flashing when the power of UPS is supplied by utility.	The voltage of batteries is too low or the batteries haven't been connected	Check out the batteries part of UPS, make sure they are well connected. If there is any damage on battery packs, replace new ones ASAP

# APPENDIX B.1 SPECIFICATION

MODEL		600VA	800VA	1000VA	1250VA	1500VA	2000VA	
INPUT	Capacity	600VA	800VA	1000VA	1250VA	1500VA	2000VA	
	Voltage	100V, 110V, 120V, 220V, 230V, 240V, +/-25%, Single phase						
	Frequency	50 or 60Hz +/-5% (auto sensing)						
	Frequency (on battery)	50 or 60Hz +/-0.5%						
OUTPUT	Voltage (on battery)	Pure sine wave output at nominal +/-5%						
	Frequency (on battery)	50 or 60Hz +/-0.5%						
	Voltage Regulation AVR	AVR automatically increase output voltage 15% above input voltage if -9% to-25% of nominal. AVR decrease output voltage 15% below input voltage if+9% to +25% of nominal						
PROTECTION AND FILTERING	Spike Protection	320 Joules, 2ms						
	Unit Input	Fuse for overload & short circuit protection						
	EMI/RFI filter	10dB at 0.15MHz, 50dB at 30MHz						
	Overload Protection	UPS automatic shutdown if overload exceeds 110% of nominal at 20 second and 125% at 2 seconds.						
	Transfer Time	2~4 milliseconds, including detection time						
	Short Circuit	UPS output cut off immediately or input fuse protection						
BATTERY	Type	Hot swappable, Sealed, Maintenance-free lead acid						
	Typical Recharge Time	4 hours (to 90% of full capacity)						
	Protection	Automatic self-test & discharge protection, Replace battery indicator						
	Back – up Time	10 - 30 minutes (depending on computer load)						
PHYSICAL	Net Weight Kg(lbs)	13.8 (30.4)	14.5 (31.9)	15 (33.0)	15.8 (34.8)	25 (55.0)	30 (66.0)	
	Shipping Weight Kg(lbs)	14.8 (32.6)	15.5 (34.1)	16 (35.2)	16.8 (37.0)	27 (59.4)	32 (70.4)	
	Dimension(mm) WxDxH	140x445x200				170x450x215		
	Input Inlet	IEC 320 power inlet						
	Receptacles	NEMA 5-15R (115V)/IEC 320 female appliance coupler (230V)						
	ALARM	Battery Back-Up	Slow beeping sound (about 0.25Hz)					
Battery Low		Rapid beeping sound (about 1.00Hz)						
Overload		Continue beeping sound						
INTERFACE	RS-232 Interface	Bi-directional communication port						
APPROVALS	Safety	UL, FCC, C-UL(CSA), BSMI, CE, GS/TUV						
	Surge	Meet IEEE 587 standard						
	Warranty	Two years						
ENVIRONMENT	Operation	Elevation: 6,000m max, Humidity: 0%-95%(without condensation formation), Temperature: 0-40 deg C						
	Audible noise	<40dBA (1 meter from surface)			<45dBA (1 meter from surface)			
	Storage condition	15000 meters max. elevation						

# APPENDIX B.2 SPECIFICATION

MODEL		2500VA	3000VA	1000AL	2000AL	3000AL	
INPUT	Capacity	2500VA	3000VA	1000VA	2000VA	3000VA	
	Voltage	100V, 110V, 120V, 220V, 230V, 240V, +/-25%, Single phase					
	Frequency	50 or 60Hz +/-5% (auto sensing)					
OUTPUT	Voltage (on battery)	Pure sine wave output at nominal +/-5%					
	Frequency (on battery)	50 or 60Hz +/-0.5%					
	Voltage Regulation AVR	AVR automatically increase output voltage 15% above input voltage if -9% to-25% of nominal. AVR decrease output voltage 15% below input voltage if +9% to +25% of nominal					
PROTECTION AND FILTERING	Spike Protection	320 Joules, 2ms					
	Unit Input	Breaker for overload & short circuit protection					
	EMI/RFI filter	10dB at 0.15MHz, 50dB at 30MHz					
	Overload Protection	UPS automatic shutdown if overload exceeds 110% of nominal at 20 second and 125% at 2 seconds.					
	Transfer Time	2~4 milliseconds, including detection time					
	Short Circuit	UPS output cut off immediately or input fuse protection					
BATTERY	Type	Hot swappable, Sealed, Maintenance-free lead acid					
	Typical Battery Life	3 to 6 years, depending on number of discharge cycles and ambient temperature					
	Typical Recharge Time	4 hours (to 90% of full capacity)					
	Nominal Battery Voltage	48V	48V	24V	48V	48V	
	Charge Current	2A	2A	4A	4A	4A	
	Supplied Battery Packs	Built-in	External Pack	Upon request	Upon request	Upon request	
	Protection	Automatic self-test & discharge protection, Replace battery indicator					
	Back – up Time	10 – 30 minutes (depending on computer load)					
PHYSICAL	Net Weight Kg(lbs)	30 (66.1)	110V 20.2 (44.5)	220V 19 (41.9)	10 (22.0)	19 (41.9)	26.8 (59.0)
	Shipping Weight Kg(lbs)	32 (70.5)	22.7 (50)	21 (46.3)	11 (22.2)	21 (46.3)	29.3 (64.5)
	Dimension(mm) WxDxH	170 x450 x226	170 x580 x226	170 x450 x226	140 x436 x210	170 x450 x226	170 x580 x226
	Input Inlet	IEC 320 power inlet					
	Receptacles	NEMA 5-15R (115V)/IEC 320 female appliance coupler (230V)					



# APPENDIX B.3 SPECIFICATION

MODEL		2500VA	3000VA	1000AL	2000AL	3000AL
ALARM	Battery Back-Up	Slow beeping sound (about 0.25Hz)				
	Battery Low	Rapid beeping sound (about 1.00Hz)				
	Overload	Continue beeping sound				
INTERFACE	RS-232 Interface	Bi-directional communication port				
APPROVALS	Safety approvals	UL, C-UL(CSA)-UL 1778 CE/LVD, GS/TUV-EN50091 & EN60950				
	EMC verifications	CISPER 22 Class B verified (FCC,BSMI,CE/EMC)				
	Electromagnetic immunity	IEC-801-2 level IV, 801-3 level III, 801-4 level IV				
	Surge	Meet IEEE 587 standard				
	Warranty	Two years				
ENVIRONMENT	Operating Temperature	0 °C to +48 °C				
	Storage Temperature	-15 °C to +45 °C				
	Operating and storage relative humidity	0 to 95%, non-condensing				
	Operating elevation	0 to +3500 m				
	Storage elevation	0 to +15000m				
	Audible noise	<40dBA (1 meter from surface)			<45dBA (1 meter from surface)	

Note  
Characteristics are subject to change without prior notice

# APPENDIX B.4 SPECIFICATION

MODEL		800 VA RM	1000 VA RM	1250 VA RM	1500 VA RM	2000 VA RM	2500 VA RM	600VA RM (2U)
INPUT	Capacity	800 VA	1000 VA	1250 VA	1500 VA	2000 VA	2500 VA	600 VA
	Voltage	100V, 110V, 120V, 220V, 230V, 240V, +/-25%, Single phase						
	Frequency	50 or 60Hz +/-5 Hz (auto sensing)						
OUTPUT	Voltage (on battery)	Pure sine wave output at nominal +/-5%						
	Frequency (on battery)	50 or 60Hz +/-0.5%						
	Voltage Regulation AVR	AVR automatically increase output voltage 15% above input voltage if -9% to-25% of nominal. AVR decrease output voltage 15% below input voltage if +9% to +25% of nominal						
PROTECTION AND FILTERING	Spike Protection	320 Joules, 2ms						
	Unit Input	Fuse for overload & short circuit protection						
	EMI/RFI filter	10Db at 0.15MHz, 50dB at 30MHz						
	Overload Protection	UPS automatic shutdown if overload exceeds 110% of nominal at 20 second and 125% at 2 seconds.						
	Transfer Time	2~4 milliseconds, including detection time						
	Short Circuit	UPS output cut off immediately or input fuse protection						
BATTERY	Type	Hot swappable, Sealed, Maintenance-free lead acid						
	Typical Recharge Time	4 hours (to 90% of full capacity)						
	Protection	Automatic self-test & discharge protection, Replace battery indicator						
	Back – up Time	10 - 30 minutes (depending on computer load)						
PHYSICAL	Net Weight Kg(lbs)	18.0 (39.6)	18.0 (39.6)	23.5 (51.7)	26.1 (57.4)	28.4 (62.4)	28.4 (62.4)	15.7 (34.6)
	Shipping Weight Kg(lbs)	19.5 (42.9)	19.5 (42.9)	25.0 (55.0)	27.7 (60.9)	30.0 (66.0)	30.0 (66.0)	18.7 (41.2)
	Dimension (mm) WxDxH	483x381x130						483 x351 x84
	Input Inlet	IEC 320 power inlet						
	Receptacles	NEMA 5-15R (115V)/IEC 320 female appliance coupler (230V)						
	Storage condition	15000 meters max. elevation						

# APPENDIX B.5 SPECIFICATION

MODEL		800 VA RM	1000V A RM	1250V A RM	1500V A RM	2000V A RM	2500V A RM	600VA RM (2U)	
ALARM	Battery Back-Up	Slow beeping sound (about 0.25Hz)							
	Battery Low	Rapid beeping sound (about 1.00Hz)							
	Overload	Continue beeping sound							
INTERFACE	RS-232 Interface	Bi-directional communication port							
CONFORMANCE	Safety approvals	UL, C-UL(CSA)-UL 1778 CE/LVD, GS/TUV-EN50091 & EN60950							
	EMC verifications	CISPER 22 Class B verified (FCC,BSMI,CE/EMC)							
	Electromagnetic immunity	IEC-801-2 level IV, 801-3 level III, 801-4 level IV							
	Surge	Meet IEEE 587 standard							
	Warranty	Two years							
ENVIRONMENT	Operating Temperature	0 °C to +40 °C							
	Storage Temperature	-15 °C to +45 °C							
	Operating and storage relative humidity	0 to 95%, non-condensing							
	Operating elevation	0 to +3000 m							
	Storage elevation	0 to +15000m							
	Audible noise	<40dBA (1 meter from surface)				<45dBA (1 meter from surface)			

Note: Characteristics are subject to change without prior notice